

GA-1350-C
Angle grinder w/ 3pc collet
13,500 RPM

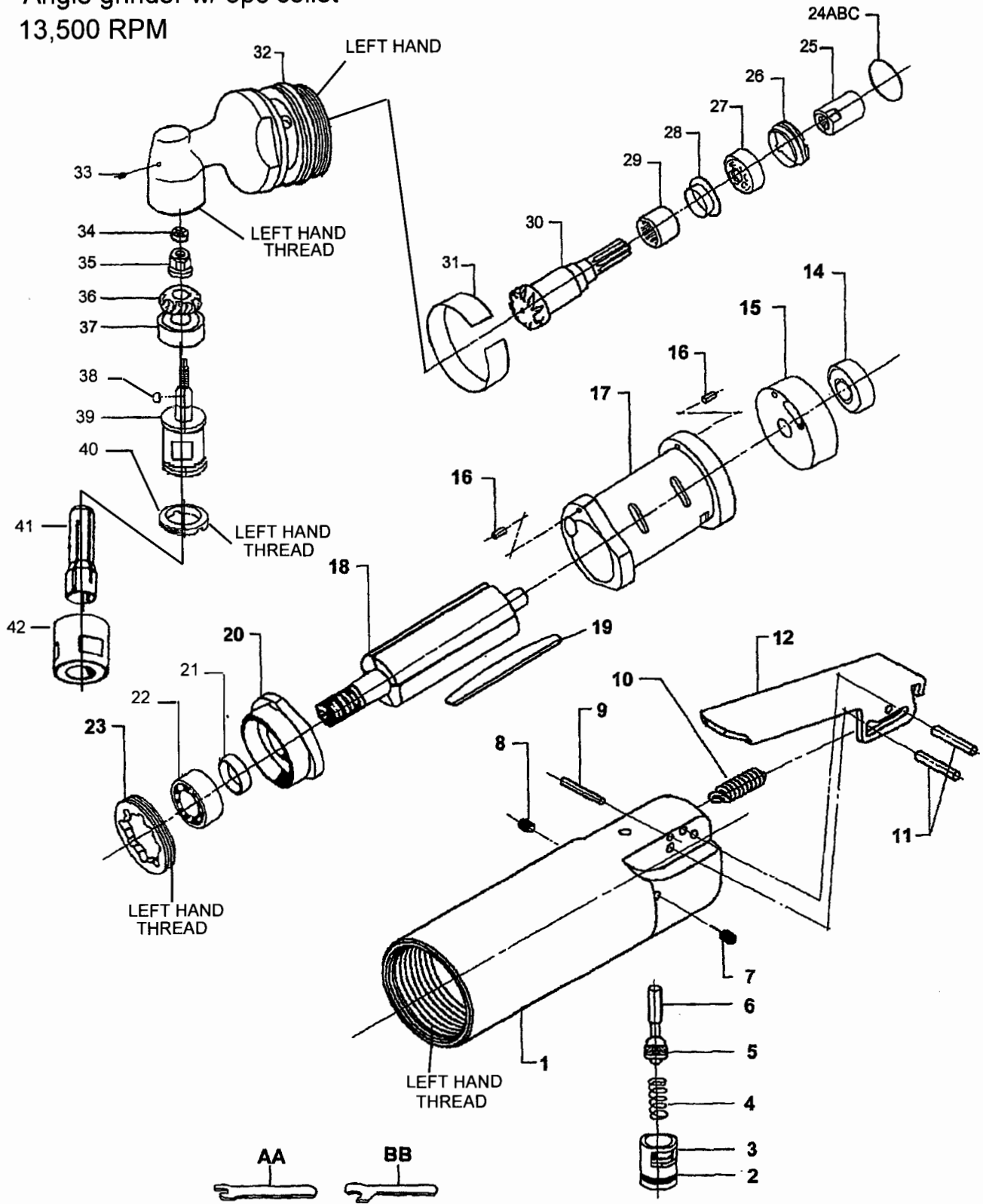

**GA-1350-C Angle Grinder
w/1/4" collet 13,500 RPM**

PATCO AIR TOOLS

www.patcoairtools.com

800-727-2201

Index	Description	Part	Qty
1	Motor Housing steel (G-3316A-135 Alum.)	G-3316-135	1
2	O-Ring	G-3001	1
3	Regulator Cap	G-3319	1
4	Spring Throttle Valve	G-3181	1
5	O-Ring	G-3083	1
6	Throttle Valve	G-3179	1
7	Set Screw - dognose	G-3193	1
8	Set Screw - blunt	GA-3293	1
9	Spring pin	G-3726	1
10	Spring	G-3098	1
11	Roll Pin	G-3660	2
12	Lever	G-3087	1
14	Ball Bearing	G-3412	1
15	Rear End Plate	G-3182	1
16	Pin Liner	G-3791	2
17	Liner	G-3183	1
18	Rotor	G-3184	1
19	Rotor Blade	G-3191	4
20	Front End Plate	G-3185	1
21	Spacer Bearing	G-3192	1
22	Ball Bearing	G-3326	1
23	Nut Clamp	G-3187	1
24A	Shim.003	GA-3491	As required
24B	Shim.005	GA-3492	As required
24C	Shim.010	GA-3493	As required
25	Coupling	GA-3490	1
26	Nut	GA-3489	1
27	Bearing	GA-3878	1
28	Spacer	GA-3502	1
29	Bearing	GA-3494	1
30	Pinion sold as short pinion gear set	GA-3598	1
31	Deflector	GA-3190	1
32	Angle Housing	GA-3499	1
33	Fitting	GA-3661	1
34	Bearing	GA-3142	1
35	Nut	GA-3501	1
36	Gear sold as pinion gear set	GA-3598	1
37	Bearing	GA-3819	1
38	Key	GA-3227	1
39	Double Angle Collet Spindle	GA-3997	1
40	Nut	GA-3487	1
41	Collet 1/4" STD	G-3729	1
	1/8" by request	G-4158	
	3/16" by request	G-4159	
	3/8" by request	G-3375	
42	Double Angle Collet Nut	GA-3998	1
AA	Spindle wrench 9/16"	G-3858	1
BB	Nut wrench 3/4"	G-3327	1
2,5,14,19,21,22, 27,29,30,34,36,37	Short Angle Tune-up-kit	GA-3005	

GENERAL INSTRUCTIONS

Collet Angle grinders

SAFETY INSTRUCTIONS:

1. Stay alert. Watch what you are doing, and use common sense when operating a pneumatic tool. Do not use a pneumatic tool while tired or under the influence of drugs, alcohol, or medication. A moment of inattentions while operating pneumatic tools may result in serious personal injury.
2. Dress properly. Do not wear loose clothing or jewelry. Contain long hair. Keep your hair, clothing, and gloves away from moving parts. Loose clothes, jewelry, or long hair can be caught in moving parts.
3. Avoid accidental starting. Be sure the trigger is off before connecting to the air supply. Carrying pneumatic tools with your finger on the trigger, or connecting pneumatic tools to the air supply with the trigger on, invites accidents.
4. Remove adjusting keys or wrenches before turning on the tool. A wrench or key that is left attached to a rotating part of the tool may result in personal injury.
5. Do not overreach. Keep proper footing and balance at all times. Proper footing and balance enables better control of the tool in unexpected situations.
6. Use safety equipment. Always wear ANSI-approved safety glasses underneath a full-face shield, gloves and hearing protection.
7. Always shut off air supply and disconnect the tool from the air supply when servicing the tool.
8. Exposure to vibration may be harmful to hands and arms.
9. Utilize a safety program to provide regular maintenance and inspection of tools and air supply system.
10. Do not defeat, remove, and modify safety devices on the tool.
11. Do not make contact with energized electrical lines.
12. Avoid work in hazardous atmospheres where a spark could detonate fumes or ignites flammable liquids.

ADDITIONAL SAFETY REGULATIONS:

1. General Industry Safety & Health Regulations, Part 1910, OSHA 2206, available from: Sup't of Documents; Government Printing Office; Washington DC 20402
2. "Safety Code for Portable Air Tools" ANSI B186.1 available from: American National Standard Institute, Inc. 11 W. 42nd Str., New York NY 10036
3. State and local regulations.

AIR SUPPLY:

1. For best results, 90 psi of clean dry air is recommended. Use 3/8" air hose or larger with fittings of 9/32" minimum I.D. An airline regulator, lubricator and filter mounted as close to the tool as possible is also recommended for efficient performance.
2. Use clean, dry, regulated compressed air at 90PSI. Do not exceed the recommended 90-PSI. Never use oxygen, carbon dioxide, combustible gases, or any other bottled gas as a power source for this tool.
3. Prior to use, the tool requires the attachment of a quick-connector into its air inlet. To do so, wrap approximately 2" of pipe thread sealer tape (not included) around the male threads of a quick-connector then firmly tighten the quick-connector into the air inlet.
4. When connecting to the air supply: Prior to each use if an automatic oiler is not used, add two drops of Air Tool oil (not included) into the air in the tool before performing any maintenance or service.

OPERATING INSTRUCTIONS:

1. Use clamps or other practical ways to secure and support the work piece to a stable platform. Holding the work by hand is unstable and may lead to loss of control. Only work on a work piece that is properly secured.
2. Do not force the tool. Use the correct tool for your application. The correct tool will do the job better and safer at the rate for which it is designed.
3. Do not use the power tool if the trigger does not turn it on or off. Any tool that cannot be controlled with the trigger is dangerous and must be replaced.
4. Disconnect the air hose from the tool before making any adjustments, changing accessories, or storing the tool. Such preventive safety measures reduce the risk of starting the tool accidentally.
5. Store idle tools out of reach of children and other untrained persons. Tools are dangerous in the hands of untrained users.
6. Maintain tools with care. Do not use a damaged tool. Tag damaged tools "Do not use" until repaired.
7. Check for misalignment or binding of moving parts, breakages of parts, damaged air hose (not included), and any other condition that may affect the tool's operation. If damaged, have the tool serviced before using. Poorly maintained tools cause many accidents.

8. Use only accessories that are recommended by the manufacturer for your model tool. Accessories that may be suitable for one tool may become hazardous when used on another tool.
9. Tools should be used in compliance with intended design. Refer to product catalog and ANSI B186.1 AND B-7.1.
10. Operator must always wear personal protective equipment (safety goggles or face shield, hearing protection and gloves) when operating tools. Other protective equipment may be necessary. See additional safety regulations.
11. If tool is making an unusual sound or vibration, stop use immediately and have tool inspected and repaired by an authorized maintenance representative.
12. Always use mounted points or carbide burrs with a maximum speed rating equal to or exceeding the labeled speed of the tool.
13. Follow all mounted point or carbide burr manufacturer's **mounting and operating instructions**.
14. Do not use any adapters in the collet to mount a device that requires a guard.
15. Prior to performing any assembly and/or adjustment procedures, make sure the air supply hose (not included) is disconnected from the tool.
16. Some dust created by power sanding, sawing, grinding and other construction activities contains chemicals known to cause cancer, birth defects, or other reproductive harm. Some examples of these chemicals are:
Lead from lead-based paints
Crystalline silica form bricks, cement and other masonry products
Arsenic and chromium from chemically treated lumber
Your risk from exposure varies, depending now how often you do this type of work. To reduce your exposure to these chemicals: work in a well-ventilated area, and use approved personal protective equipment such as dust masks that are specially designed to filter out microscopic particles.

WORK AREA:

1. Keep your work area clean and well lit. Cluttered benches and dark areas invite accidents.
2. Do not operate pneumatic tools in explosive atmospheres, such as in the presence of flammable liquids, gases, or dust. Pneumatic tools create sparks, which may ignite flammables.
3. Keep bystanders, children and pets away while operation a pneumatic tool. Distractions can cause you to lose control. Protect others in the work area from debris such as metal filings and sparks. Provide barriers or shields as needed.

HLUBRICATION:

1. High-grade air tool oil, which contains a moisture absorbent and rust inhibiting additives, is recommended.
2. Before daily tool use, place approximately 10 drops of recommended oil into air inlet. When the tool is used continually in production work, an airline lubricator and filter is recommended, to assure adequate and constant lubrication.
3. This tool requires grease to lubricate the gear and pinion system. Use high quality gear grease. Apply two or three squirts of grease into tool head through the lubrication fitting after eight hours of use.

TROUBLE SHOOTING FOR LOSS OF POWER

1. Check air supply. Loss of power may be caused by decreased compressor output, too much drain on air supply, incorrect hose size or poor connections.
2. Dirty or wet air supply. Dirt in the air supply will damage tool. Wet air can rinse lubricant from tool and cause rust corrosion.
3. Check lubrication. The tool should be lubricated a minimum of every eight hours of use following lubrication instructions above.
4. Always disconnect the tool from its compressed air supply source, and squeeze the trigger to release all compressed air in the tool before performing any maintenance or services.
5. Mechanical parts of tool need to be checked periodically. Pay close attention to the o-rings for wear and inspect the piston for wear and free movement in the casing assembly. Tool must be returned to an authorized representative for extensive repairs.

SAVE THIS MANUAL:

The warnings, precautions, and instructions discussed in this manual cannot cover all possible conditions and situations that may occur. The operator must understand that common sense and cautions are factors, which cannot be built into the product, but must be supplied by the operator.

You will need this manual for the safety warnings and precautions, assembly, operating, inspection, maintenance and cleaning procedures, parts list and assembly diagram. Keep this manual and invoice in a safe and dry place for future reference.